

# WBD RESPONSE TO BIPOLAR AND TRIPOLAR PULSES: BENCH TESTS VS. IN FLIGHT OBSERVATIONS

J.M. Swanner, J.S. Pickett, J.R. Phillips, D.L. Kirchner

Department of Physics and Astronomy, The University of Iowa, Iowa City, Iowa 52242, USA

## 1. ABSTRACT

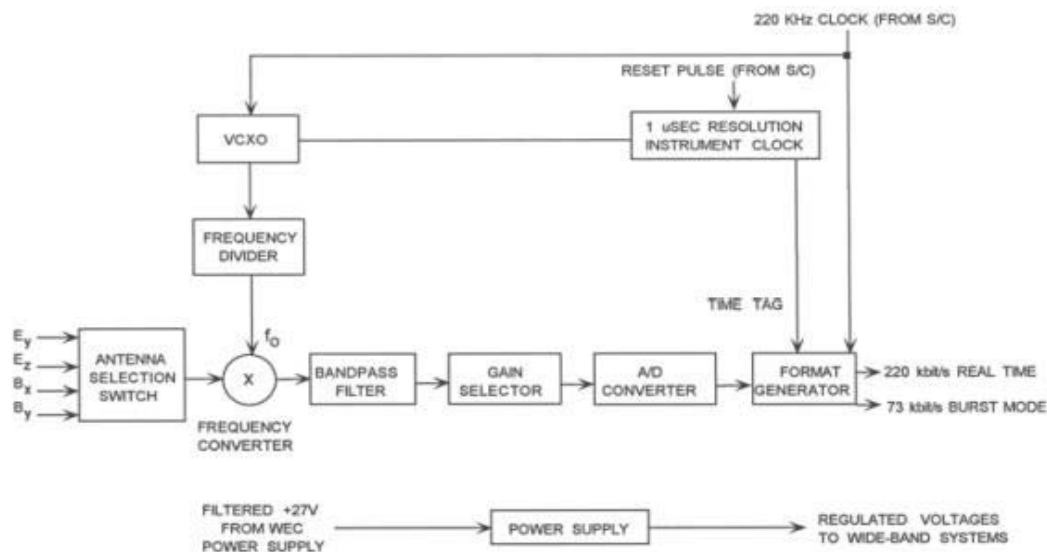
The Cluster Wide-Band (WBD) Plasma Wave Receiver is one of the five instruments that make up the Wave Experiment Consortium (WEC) onboard each of the four spacecraft that make up the Cluster II mission. The WBD Receiver is a digital instrument that provides high resolution waveform measurements and that was optimally designed as a detector of multicycle sinusoidal waveforms. All the pre-launch testing and calibration was carried out using white noise or set frequency sinusoidal signal inputs instead of isolated electrostatic pulses, similar to those commonly observed in Earth's outer boundary layers, magnetosheath, solar wind and auroral areas. The investigation was carried out using the Cluster WBD Flight Spare to test its response to known input pulses. It was observed that an input pulse was distorted when the time duration of the pulse approached or surpassed the calculated RC time constant for the particular bandpass filter output mode.

## 2. MOTIVATION BEHIND INVESTIGATION

The Cluster Wide-Band (WBD) Plasma Wave Receiver is one of five instruments that comprise the Cluster Wave Experiment Consortium (WEC) onboard each of the four spacecraft that comprise the Cluster II mission [2]. The WBD receiver is a digital instrument that provides high resolution waveform measurements over a wide range of frequencies along one axis only [1]. It is capable of obtaining both electric or magnetic measurements in the frequency range of 100 Hz to 577kHz, where the time resolution may be anywhere between 5-36 microseconds and is dependant on the operating mode of the instrument [4]. The three different bandpass filters available for measurements are 9.5 kHz, 19 kHz, and 77 kHz, along with 4 different possibilities for conversion frequencies of 0 kHz, 125 kHz, 250 kHz, and 500 kHz. There are four antennas that provide the input signal to the WBD receiver. The input selection is determined by the antenna selection switch. There are two electric-field inputs,  $E_y$  and  $E_z$ , and two magnetic field inputs,  $B_x$  and  $B_y$ , provided by the Electric Field and Wave (EFW) experiment and the Spatio-Temporal Analysis of Electric and Magnetic Field Fluctuations (STAFF) experiment, respectively. The block diagram of the WBD instrument is shown in Figure 1 from [1].

The WBD Receiver was optimally designed as a detector of multicycle sinusoidal type waves. The design and the performance of the instrument was based on expected signal observations, which did not include isolated electrostatic structures (IES) at that time. Instead, all of the pre-launch testing was carried out using white noise or set frequency sinusoidal signal inputs. The procedures for the calibration testing were conducted after all the models had been assembled using unit level testing. This enabled any differences in performance between models to be clearly identified. More calibration tests were conducted during the integration level of the instrument with the other onboard instruments since it uses signals from two other experiments [1].

IES are frequently observed by Cluster at all of Earth's boundary layers and in the magnetosheath, solar wind and auroral area from 4.5-6.5 $R_E$ . There are two main types of IES, also called electrostatic solitary waves, solitary waves or isolated impulses. The first type is a bipolar pulse which consists of an electrostatic pulse that has one positive peak and one negative peak. An example of a bipolar pulse is shown as the reference input signal in Figure 3. The second type is a tripolar pulse which consists of two positive peaks and a negative peak in the middle, or two negative peaks and a positive peak in the middle [3]. An example of a distorted bipolar that resembles a tripolar pulse is shown in Figure 4.

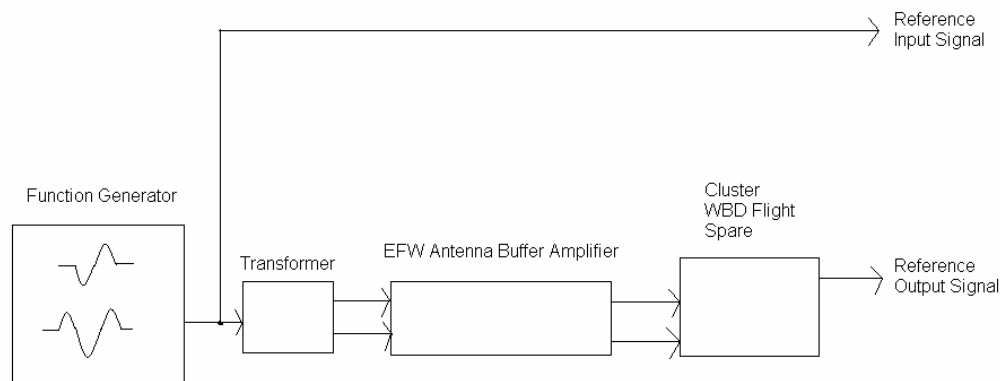


**Figure 1.** Block diagram of the WBD instrument.

### 3. TEST SETUP

In order to correctly interpret the solitary waves observed in these Cluster data it was necessary to test the WBD receiver response to known input pulses with a test setup as close as possible to the in-flight setup. The known input pulses were provided by a function generator. The signal produced by the function generator was measured separately to obtain the reference input signal. The transformer used the same signal produced from the function generator as a single ended input to generate two output differentials. This simulates the input onboard Cluster generated from two different antennas that provide a dipole input implemented as two monopoles as experienced in flight. The EFW Antenna Buffer Amplifier was designed to be a high voltage/ low frequency high pass filter which has a protective characteristic which filters out large voltage spikes from the input. The input is then passed to the fully qualified Cluster WBD Flight Spare. The reference output signal then clearly demonstrates any distortion in the signal generated as compared to the reference input signal. The impulse response test setup is shown in Figure 2.

#### Impulse Response Test Setup



**Figure 2.** Block diagram of the Impulse Response Test Setup

#### 4. TEST DATA

The input pulse for the test data for both the bipolar and tripolar cases was generated by a function generator and its waveform was printed from an oscilloscope display shown in the top right of Figures 3 and 4. The time duration of each pulse for every case was approximately measured using the oscilloscope tick marks. The horizontal major tick interval and vertical major tick interval for each input pulse is reported in the top left of Figures 3 and 4. The output reference signal is shown in the bottom right of Figures 3 and 4. The selected antenna value for the input to the WBD receiver was  $E_z$  which is shown in instrument status in the lower left of Figures 3 and 4. The output reference pulse for each case was printed from the Cluster ground support equipment. For each bandpass filter, the RC time constant was calculated.

#### 5. SUMMARY OF THE TEST DATA

Tables 1 and 2 summarize the test data for bipolar and tripolar pulses respectively. The first column designates the tested frequency. The second column gives the RC time constant calculated using the equation  $1/2\pi f$ , where  $f$  is the 3dB point, or cutoff frequency. The 3dB point of the EFW antenna buffer amplifier is approximately 100 Hz, which was the value used to calculate the RC time constant in Tables 1 and 2 for the 9.5 kHz and 19 kHz cases. The value of  $f$  used in the 77 kHz case was 700 Hz, the 3dB point of the WBD bandpass filter.

**Table 1.** Test Data Results for Bipolar Pulses

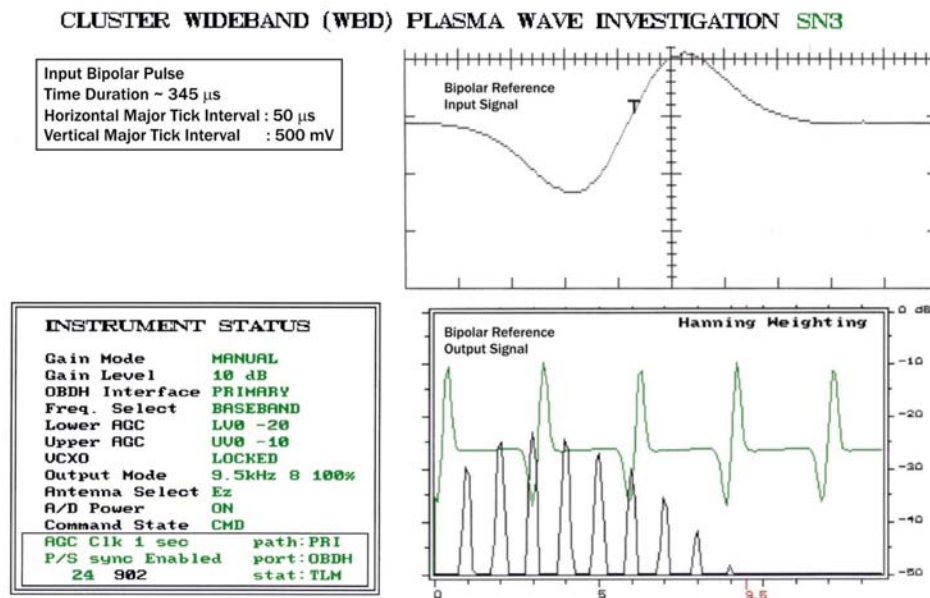
	RC Time Constant $1/2\pi f$	Time Pulse Duration (Very Good)	Time Pulse Duration (Turning Point)	Time Pulse Duration (Very Bad)
9.5 kHz	1590 $\mu$ s	~345 $\mu$ s	~800 $\mu$ s	~1700 $\mu$ s
19 kHz	1590 $\mu$ s	~180 $\mu$ s	~800 $\mu$ s	~1120 $\mu$ s
77 kHz	230 $\mu$ s	~51 $\mu$ s	~225 $\mu$ s	~345 $\mu$ s

**Table 2.** Test Data Results for Tripolar Pulses

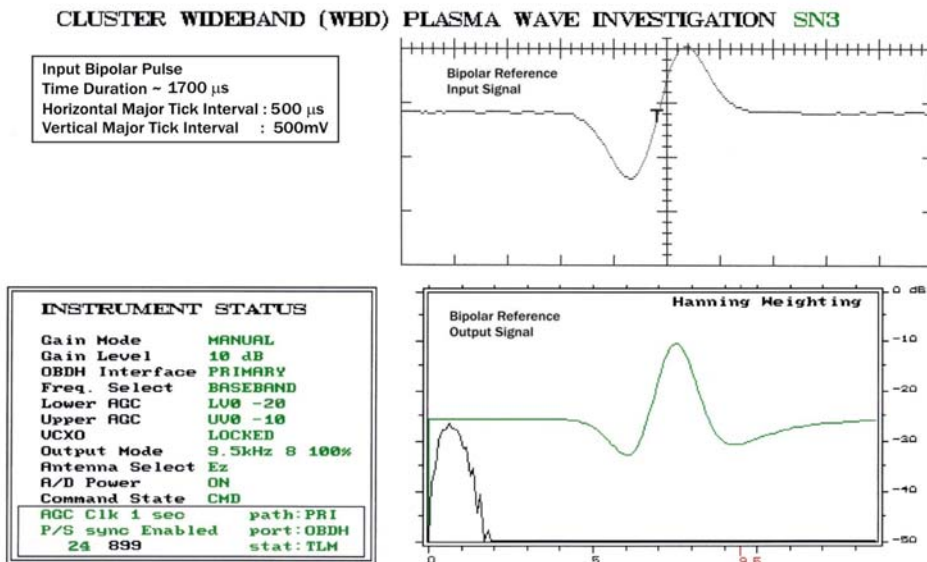
	RC Time Constant $1/2\pi f$	Time Pulse Duration (Very Good)	Time Pulse Duration (Turning Point)	Time Pulse Duration (Very Bad)
9.5 kHz	1590 $\mu$ s	~345 $\mu$ s	~800 $\mu$ s	~1700 $\mu$ s
19 kHz	1590 $\mu$ s	~180 $\mu$ s	~800 $\mu$ s	~1120 $\mu$ s
77 kHz	230 $\mu$ s	~51 $\mu$ s	~225 $\mu$ s	~345 $\mu$ s

## 6. UNDERSTANDING THE TEST RESULTS

In both the 9.5 kHz and the 19kHz cases, the results were similar. This is in part since each are affected by the EFW antenna buffer amplifier. In both cases, a shorter time duration pulse is distorted very little. On the contrary, a longer pulse that is either approaching the RC time constant value time duration, calculated as  $1590\mu\text{s}$ , or is higher becomes greatly distorted. As an example, an input bipolar pulse that is fairly short in time duration as compared to the calculated RC time constant, was measured to be approximately  $345\mu\text{s}$ , as shown in the upper right of Figure 3. Using the 9.5 kHz output mode, the resulting signal is also clearly a bipolar pulse as shown in the lower right of Figure 3. This example demonstrates that it maintains its symmetric shape of one negative peak and one positive peak. On the contrary, an input bipolar reference input signal that is longer than the RC time constant as shown in the upper right of Figure 4, is distorted by overshooting and undershooting and resembles a tripolar pulse as shown in the lower right of Figure 4. Similarly, in the tripolar cases for both the 9.5 kHz and the 19 kHz modes, the distortion effect caused the input pulses that were close to or exceeding the calculated RC time constant to resemble bipolar pulses at the output.

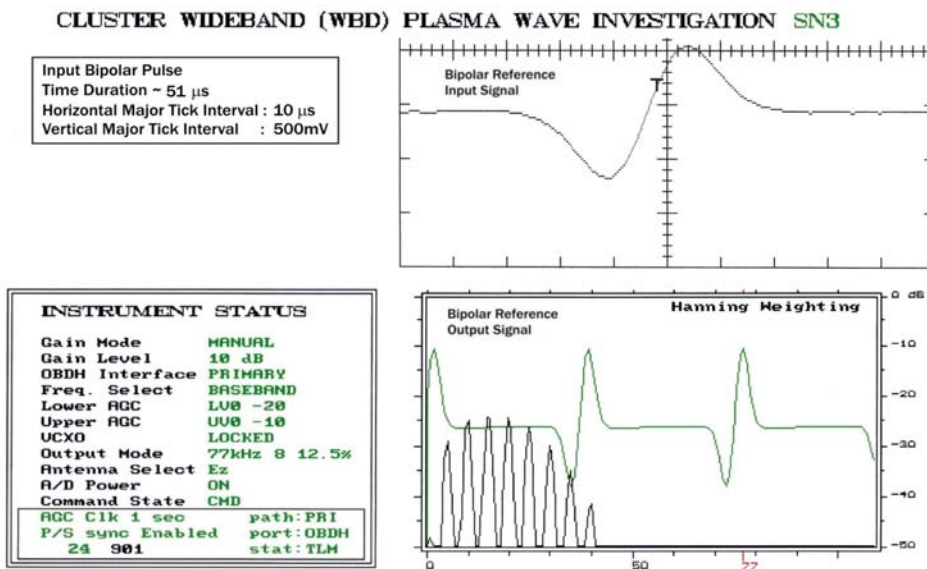


**Figure 3.** Example of Bipolar Pulse Input Reference Signal and Undistorted Bipolar Pulse Reference Output Signal in the 9.5 kHz Output Mode



**Figure 4.** Example of Bipolar Pulse Input Reference Signal and Distorted Bipolar Pulse Reference Output Signal in the 9.5 kHz Output Mode

In the 77 kHz output mode, the limiting device is the WBD Flight Spare. The 3dB point is approximately 700 Hz, which was the value used to calculate the RC time constant as 230 $\mu$ s in the above tables. In the 77 kHz mode, only the input bipolar pulse, shown in the upper right of Figure 5, resulted in an undistorted output bipolar pulse as shown in the lower right of Figure 5. There was no available example for an undistorted tripolar pulse. However, it may be assumed that the results would be similar to the bipolar results in the 77 kHz mode based on the results for the 9.5 kHz and 19 kHz modes. See Appendix A for examples of all cases presented in Tables 1 and 2, except the one case in the 77 kHz mode for which there is no available example of an undistorted tripolar pulse.



**Figure 5.** Example of Bipolar Pulse Input Reference Signal and Undistorted Bipolar Pulse Reference Output Signal in the 77 kHz Output Mode

**REFERENCES**

1. Gurnett, D.A., Huff, R. L., and Kirchner, D. L., The Wide-Band Plasma Wave Investigation, *Space Science Reviews*, Vol 79, 195-208, 1997.
2. Pedersen, A., Cornilleau-Wehrin, N., Porte, B. De La, Roux, A., Bouabdellah, A., et al., The Wave Experiment Consortium (WEC), *Space Science Reviews*, Vol 79, 93-105, 1997.
3. Pickett, J.S., Chen, L.-J., Kahler, S.W., Santolik, O., Gurnett, D.A., Tsurutani, B.T., and Balogh, A., Isolated Electrostatic Structures Observed Throughout the Cluster Orbit: Relationship to Magnetic Field Strength, *Annales Geophysicae*, 22, 2515-2523, July 2004.
4. Pickett, J. S., Seeberger, J. M., Swanner, J. M., Gurnett, D.A., Cluster WBD Data and the Cluster Active Arhive, *Proceedings of the Cluster and Double Star Symposium—5<sup>th</sup> Anniversary of Cluster in Space*, Karen Fletcher, Editor, ESA Publications Division, Noordwijk, The Netherlands, SP-598, January 2006.

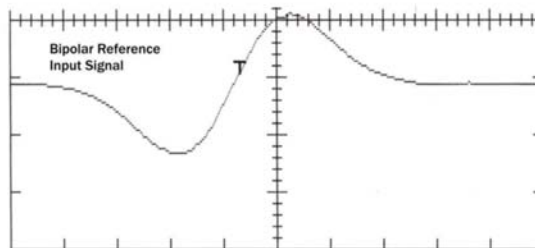
## APPENDIX A

### 1. Bipolar Pulses

#### a. 9.5 kHz Output Mode

##### CLUSTER WIDEBAND (WBD) PLASMA WAVE INVESTIGATION SN3

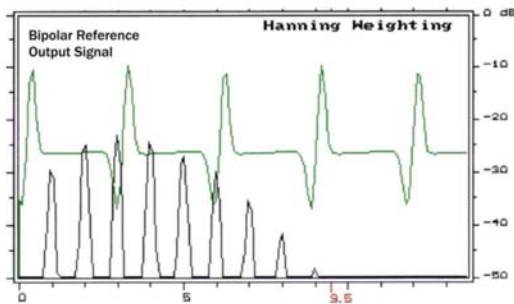
Input Bipolar Pulse  
 Time Duration ~ 345  $\mu$ s  
 Horizontal Major Tick Interval : 50  $\mu$ s  
 Vertical Major Tick Interval : 500 mV



**INSTRUMENT STATUS**

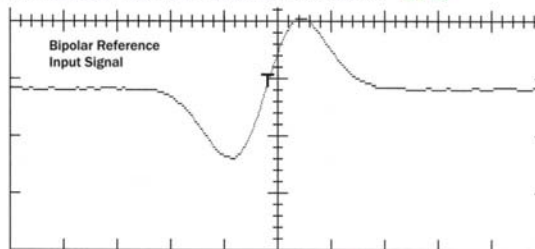
Gain Mode MANUAL  
 Gain Level 10 dB  
 OBDH Interface PRIMARY  
 Freq. Select BASEBAND  
 Lower AGC LV0 -20  
 Upper AGC UV0 -10  
 UCXO LOCKED  
 Output Mode 9.5kHz 8 100%  
 Antenna Select Ez  
 A/D Power ON  
 Command State CMD

AGC Clk 1 sec path:PRI  
 P/S sync Enabled port:OBDH  
 24 902 stat:TLM



##### CLUSTER WIDEBAND (WBD) PLASMA WAVE INVESTIGATION SN3

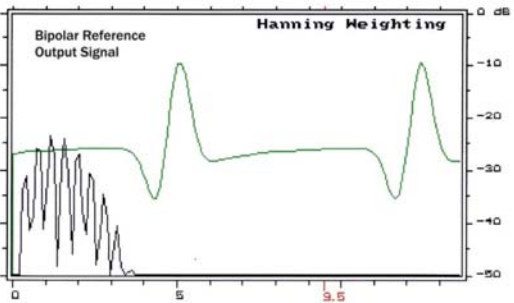
Input Bipolar Pulse  
 Time Duration ~ 800  $\mu$ s  
 Horizontal Major Tick Interval : 200  $\mu$ s  
 Vertical Major Tick Interval : 500mV



**INSTRUMENT STATUS**

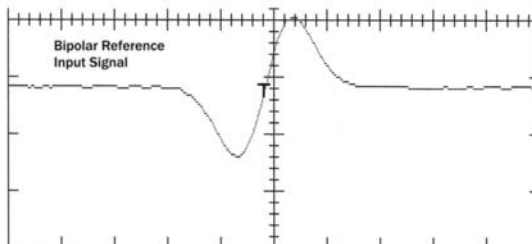
Gain Mode MANUAL  
 Gain Level 10 dB  
 OBDH Interface PRIMARY  
 Freq. Select BASEBAND  
 Lower AGC LV0 -20  
 Upper AGC UV0 -10  
 UCXO LOCKED  
 Output Mode 9.5kHz 8 100%  
 Antenna Select Ez  
 A/D Power ON  
 Command State CMD

AGC Clk 1 sec path:PRI  
 P/S sync Enabled port:OBDH  
 24 902 stat:TLM



CLUSTER WIDEBAND (WBD) PLASMA WAVE INVESTIGATION SN3

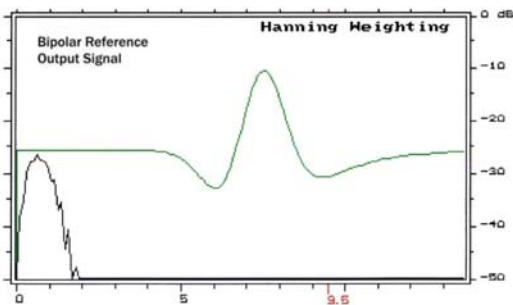
Input Bipolar Pulse  
 Time Duration ~ 1700  $\mu$ s  
 Horizontal Major Tick Interval : 500  $\mu$ s  
 Vertical Major Tick Interval : 500mV



**INSTRUMENT STATUS**

Gain Mode MANUAL  
 Gain Level 10 dB  
 OBDH Interface PRIMARY  
 Freq. Select BASEBAND  
 Lower AGC LV0 -20  
 Upper AGC UV0 -10  
 UCXO LOCKED  
 Output Mode 9.5kHz 8 100%  
 Antenna Select Ez  
 A/D Power ON  
 Command State CMD

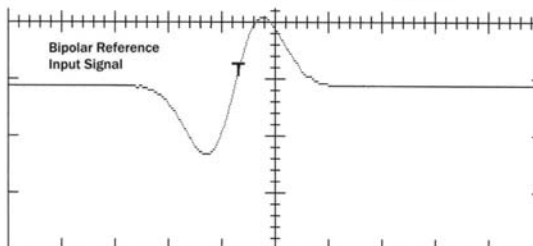
AGC Clk 1 sec path:PRI  
 P/S sync Enabled port:OBDH  
 24 899 stat:TLM



b. 19 kHz Output Mode

CLUSTER WIDEBAND (WBD) PLASMA WAVE INVESTIGATION SN3

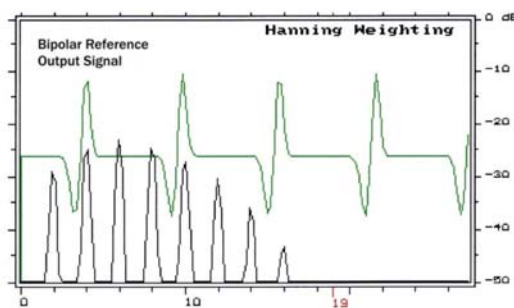
Input Bipolar Pulse  
 Time Duration ~ 180  $\mu$ s  
 Horizontal Major Tick Interval : 50  $\mu$ s  
 Vertical Major Tick Interval : 500mV



**INSTRUMENT STATUS**

Gain Mode MANUAL  
 Gain Level 10 dB  
 OBDH Interface PRIMARY  
 Freq. Select BASEBAND  
 Lower AGC LV0 -20  
 Upper AGC UV0 -10  
 UCXO LOCKED  
 Output Mode 19kHz 8 50%  
 Antenna Select Ez  
 A/D Power ON  
 Command State CMD

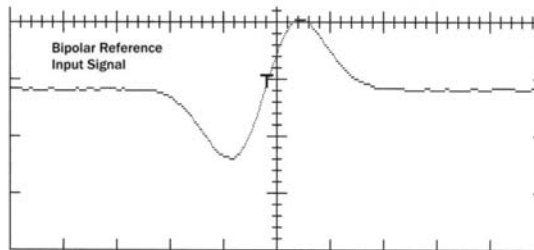
AGC Clk 1 sec path:PRI  
 P/S sync Enabled port:OBDH  
 24 901 stat:TLM





CLUSTER WIDEBAND (WBD) PLASMA WAVE INVESTIGATION SN3

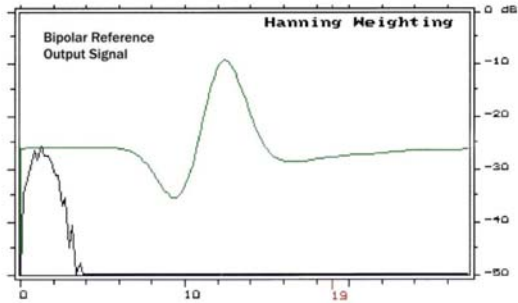
Input Bipolar Pulse  
 Time Duration ~ 800  $\mu$ s  
 Horizontal Major Tick Interval : 200  $\mu$ s  
 Vertical Major Tick Interval : 500mV



**INSTRUMENT STATUS**

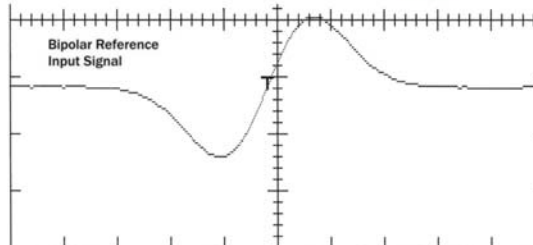
Gain Mode           MANUAL  
 Gain Level         10 dB  
 OBDH Interface    PRIMARY  
 Freq. Select      BASEBAND  
 Lower AGC         LV0 -20  
 Upper AGC         UV0 -10  
 UCX0              LOCKED  
 Output Mode       19kHz 8 50%  
 Antenna Select    Ez  
 A/D Power         ON  
 Command State    CMD

AGC Clk 1 sec     path:PRI  
 P/S sync Enabled   port:OBDH  
 24 902            stat:TLM



CLUSTER WIDEBAND (WBD) PLASMA WAVE INVESTIGATION SN3

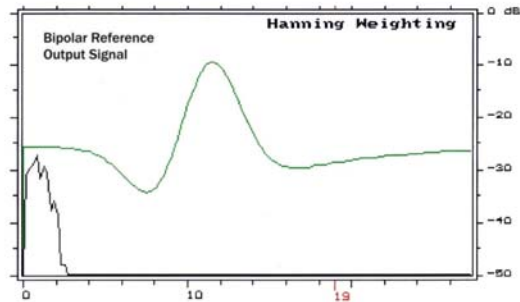
Input Bipolar Pulse  
 Time Duration ~ 1120  $\mu$ s  
 Horizontal Major Tick Interval : 200  $\mu$ s  
 Vertical Major Tick Interval : 500mV



**INSTRUMENT STATUS**

Gain Mode           MANUAL  
 Gain Level         10 dB  
 OBDH Interface    PRIMARY  
 Freq. Select      BASEBAND  
 Lower AGC         LV0 -20  
 Upper AGC         UV0 -10  
 UCX0              LOCKED  
 Output Mode       19kHz 8 50%  
 Antenna Select    Ez  
 A/D Power         ON  
 Command State    CMD

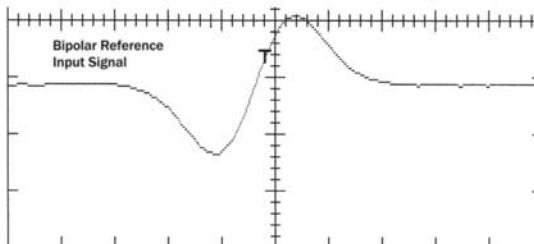
AGC Clk 1 sec     path:PRI  
 P/S sync Enabled   port:OBDH  
 24 903            stat:TLM



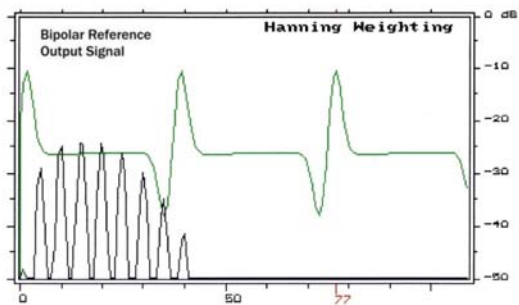
c. 77 kHz Output Mode

CLUSTER WIDEBAND (WBD) PLASMA WAVE INVESTIGATION SN3

Input Bipolar Pulse  
 Time Duration ~ 51  $\mu$ s  
 Horizontal Major Tick Interval : 10  $\mu$ s  
 Vertical Major Tick Interval : 500mV

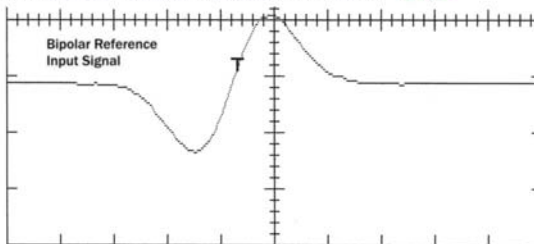


INSTRUMENT STATUS	
Gain Mode	MANUAL
Gain Level	10 dB
OBDR Interface	PRIMARY
Freq. Select	BASEBAND
Lower AGC	UV0 -20
Upper AGC	UV0 -10
UCX0	LOCKED
Output Mode	77kHz 8 12.5%
Antenna Select	Ez
A/D Power	ON
Command State	CMD
AGC Clk 1 sec	path:PRI
P/S sync Enabled	port:OBDR
24 901	stat:TLM

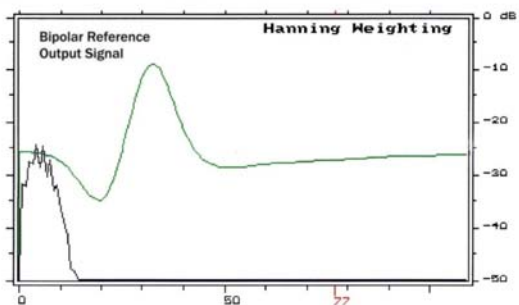


CLUSTER WIDEBAND (WBD) PLASMA WAVE INVESTIGATION SN3

Input Bipolar Pulse  
 Time Duration ~ 225  $\mu$ s  
 Horizontal Major Tick Interval : 50  $\mu$ s  
 Vertical Major Tick Interval : 500mV

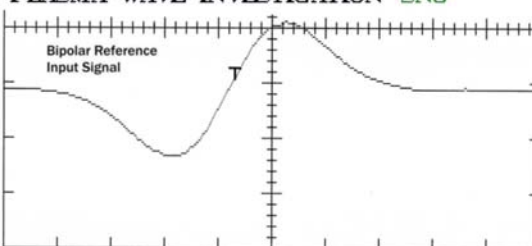


INSTRUMENT STATUS	
Gain Mode	MANUAL
Gain Level	10 dB
OBDR Interface	PRIMARY
Freq. Select	BASEBAND
Lower AGC	UV0 -20
Upper AGC	UV0 -10
UCX0	LOCKED
Output Mode	77kHz 8 12.5%
Antenna Select	Ez
A/D Power	ON
Command State	CMD
AGC Clk 1 sec	path:PRI
P/S sync Enabled	port:OBDR
24 902	stat:TLM



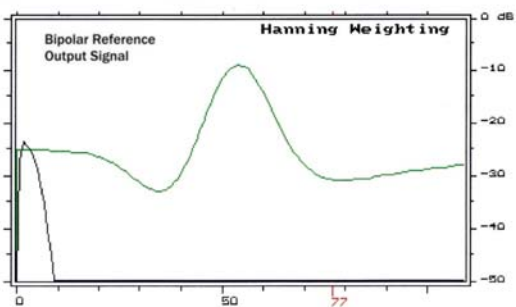
CLUSTER WIDEBAND (WBD) PLASMA WAVE INVESTIGATION SN3

Input Bipolar Pulse  
 Time Duration ~ 345  $\mu$ s  
 Horizontal Major Tick Interval : 50  $\mu$ s  
 Vertical Major Tick Interval : 500mV



**INSTRUMENT STATUS**

Gain Mode	MANUAL
Gain Level	10 dB
OBDH Interface	PRIMARY
Freq. Select	BASEBAND
Lower AGC	UV0 -20
Upper AGC	UV0 -10
UCX0	LOCKED
Output Mode	77kHz 8 12.5%
Antenna Select	Ez
A/D Power	ON
Command State	CMD
AGC Clk 1 sec	path:PRI
P/S sync Enabled	port:OBDH
24 903	stat:TLM

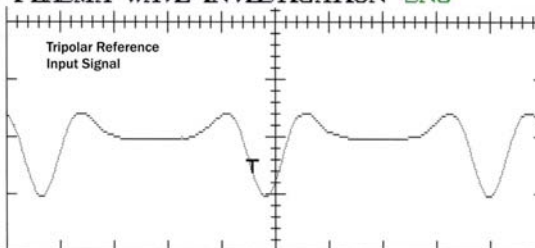


1. Tripolar Pulses

a. 9.5 kHz Output Mode

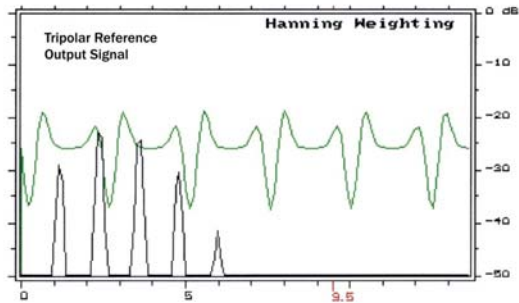
CLUSTER WIDEBAND (WBD) PLASMA WAVE INVESTIGATION SN3

Input Tripolar Pulse  
 Time Duration ~ 600  $\mu$ s  
 Horizontal Major Tick Interval : 200  $\mu$ s  
 Vertical Major Tick Interval : 50mV



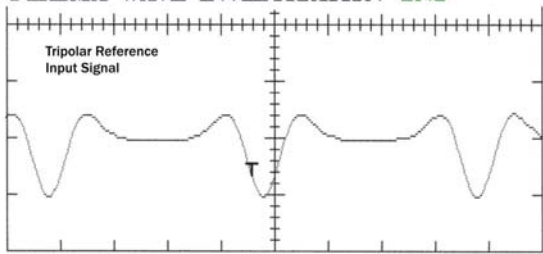
**INSTRUMENT STATUS**

Gain Mode	MANUAL
Gain Level	30 dB
OBDH Interface	PRIMARY
Freq. Select	BASEBAND
Lower AGC	UV0 -20
Upper AGC	UV0 -10
UCX0	LOCKED
Output Mode	9.5kHz 8 100%
Antenna Select	Ez
A/D Power	ON
Command State	CMD
AGC Clk 1 sec	path:PRI
P/S sync Enabled	port:OBDH
24 879	stat:TLM



CLUSTER WIDEBAND (WBD) PLASMA WAVE INVESTIGATION SN3

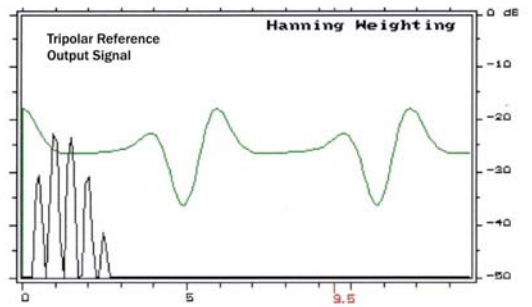
Input Tripolar Pulse  
 Time Duration ~ 1450  $\mu$ s  
 Horizontal Major Tick Interval : 500  $\mu$ s  
 Vertical Major Tick Interval : 50mV



**INSTRUMENT STATUS**

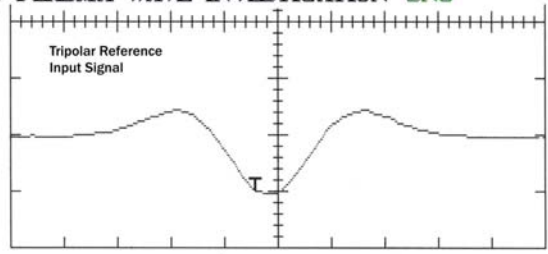
Gain Mode MANUAL  
 Gain Level 30 dB  
 OBDH Interface PRIMARY  
 Freq. Select BASEBAND  
 Lower AGC LV0 -20  
 Upper AGC UV0 -10  
 UCXO LOCKED  
 Output Mode 9.5kHz 8 100%  
 Antenna Select Ez  
 A/D Power ON  
 Command State CMD

AGC Clk 1 sec path:PRI  
 P/S sync Enabled port:OBDH  
 24 880 stat:TLM



CLUSTER WIDEBAND (WBD) PLASMA WAVE INVESTIGATION SN3

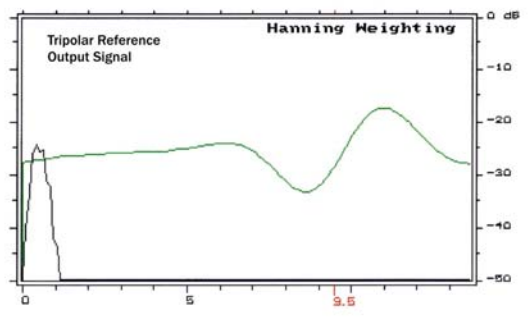
Input Tripolar Pulse  
 Time Duration ~ 3200  $\mu$ s  
 Horizontal Major Tick Interval : 500  $\mu$ s  
 Vertical Major Tick Interval : 50mV



**INSTRUMENT STATUS**

Gain Mode MANUAL  
 Gain Level 30 dB  
 OBDH Interface PRIMARY  
 Freq. Select BASEBAND  
 Lower AGC LV0 -20  
 Upper AGC UV0 -10  
 UCXO LOCKED  
 Output Mode 9.5kHz 8 100%  
 Antenna Select Ez  
 A/D Power ON  
 Command State CMD

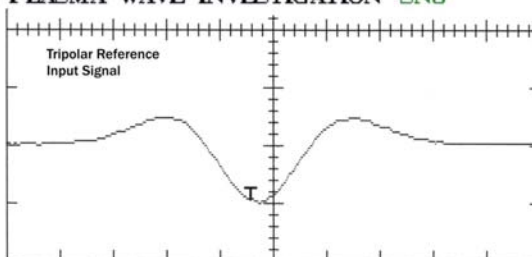
AGC Clk 1 sec path:PRI  
 P/S sync Enabled port:OBDH  
 24 883 stat:TLM



b. 19 kHz Output Mode

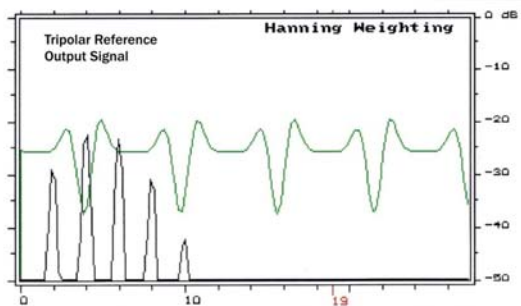
CLUSTER WIDEBAND (WBD) PLASMA WAVE INVESTIGATION SN3

Input Tripolar Pulse  
 Time Duration ~ 325  $\mu$ s  
 Horizontal Major Tick Interval : 50  $\mu$ s  
 Vertical Major Tick Interval : 50mV



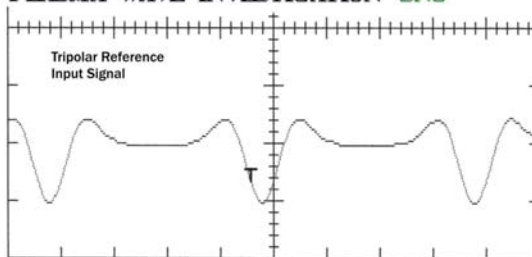
**INSTRUMENT STATUS**

Gain Mode MANUAL  
 Gain Level 30 dB  
 OBDH Interface PRIMARY  
 Freq. Select BASEBAND  
 Lower AGC LV0 -20  
 Upper AGC UV0 -10  
 UCXO LOCKED  
 Output Mode 19kHz 8 50%  
 Antenna Select Ez  
 R/D Power ON  
 Command State CMD  
 AGC Clk 1 sec path:PRI  
 P/S sync Enabled port:OBDH  
 24 880 stat:TLM



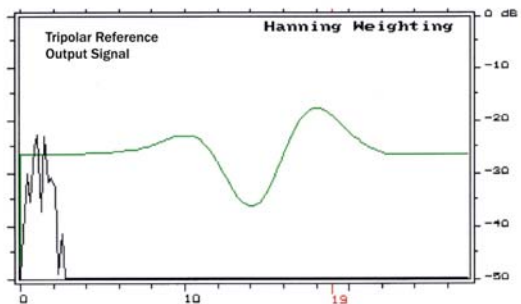
CLUSTER WIDEBAND (WBD) PLASMA WAVE INVESTIGATION SN3

Input Tripolar Pulse  
 Time Duration ~ 1450  $\mu$ s  
 Horizontal Major Tick Interval : 500  $\mu$ s  
 Vertical Major Tick Interval : 50mV



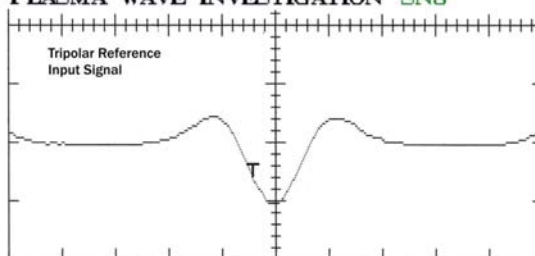
**INSTRUMENT STATUS**

Gain Mode MANUAL  
 Gain Level 30 dB  
 OBDH Interface PRIMARY  
 Freq. Select BASEBAND  
 Lower AGC LV0 -20  
 Upper AGC UV0 -10  
 UCXO LOCKED  
 Output Mode 19kHz 8 50%  
 Antenna Select Ez  
 R/D Power ON  
 Command State CMD  
 AGC Clk 1 sec path:PRI  
 P/S sync Enabled port:OBDH  
 24 944 stat:TLM



CLUSTER WIDEBAND (WBD) PLASMA WAVE INVESTIGATION SN3

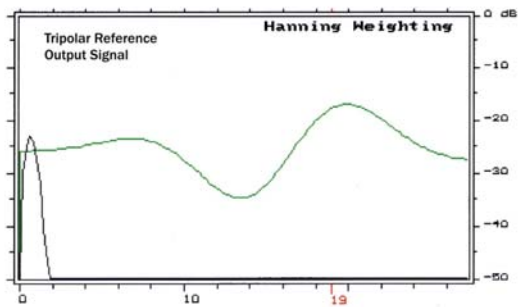
Input Tripolar Pulse  
 Time Duration ~ 2150  $\mu$ s  
 Horizontal Major Tick Interval : 500  $\mu$ s  
 Vertical Major Tick Interval : 50mV



**INSTRUMENT STATUS**

Gain Mode MANUAL  
 Gain Level 30 dB  
 OBDH Interface PRIMARY  
 Freq. Select BASEBAND  
 Lower AGC LV0 -20  
 Upper AGC UV0 -10  
 UCXO LOCKED  
 Output Mode 19kHz 8 50%  
 Antenna Select Ez  
 A/D Power ON  
 Command State CMD

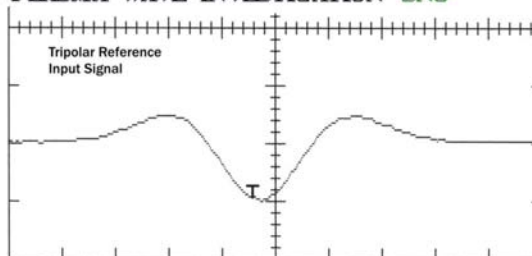
AGC Clk 1 sec path:PRI  
 P/S sync Enabled port:OBDH  
 24 882 stat:TLM



c. 77 kHz Output Mode

CLUSTER WIDEBAND (WBD) PLASMA WAVE INVESTIGATION SN3

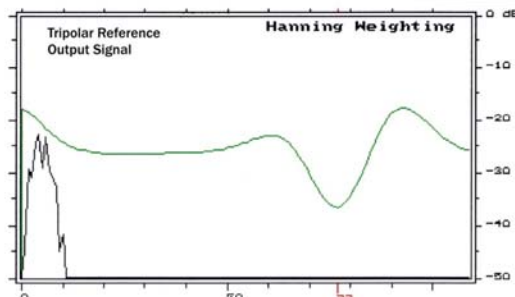
Input Tripolar Pulse  
 Time Duration ~ 325  $\mu$ s  
 Horizontal Major Tick Interval : 50  $\mu$ s  
 Vertical Major Tick Interval : 50mV



**INSTRUMENT STATUS**

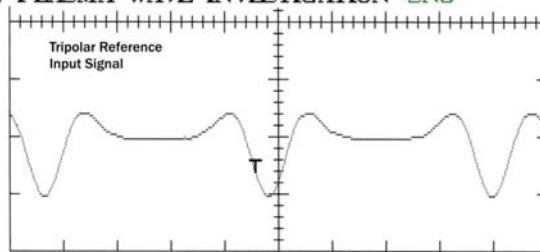
Gain Mode MANUAL  
 Gain Level 30 dB  
 OBDH Interface PRIMARY  
 Freq. Select BASEBAND  
 Lower AGC LV0 -20  
 Upper AGC UV0 -10  
 UCXO LOCKED  
 Output Mode 77kHz 8 12.5%  
 Antenna Select Ez  
 A/D Power ON  
 Command State CMD

AGC Clk 1 sec path:PRI  
 P/S sync Enabled port:OBDH  
 24 926 stat:TLM



CLUSTER WIDEBAND (WBD) PLASMA WAVE INVESTIGATION SN3

Input Tripolar Pulse  
 Time Duration ~ 600  $\mu$ s  
 Horizontal Major Tick Interval : 200  $\mu$ s  
 Vertical Major Tick Interval : 50mV



**INSTRUMENT STATUS**

Gain Mode	MANUAL
Gain Level	30 dB
OBDH Interface	PRIMARY
Freq. Select	BASEBAND
Lower AGC	UV0 -20
Upper AGC	UV0 -10
UCX0	LOCKED
Output Mode	77kHz 8 12.5%
Antenna Select	Ez
A/D Power	ON
Command State	CHD
AGC Clk 1 sec	path:PRI
P/S sync Enabled	port:OBDH
24 883	stat:TLM

